

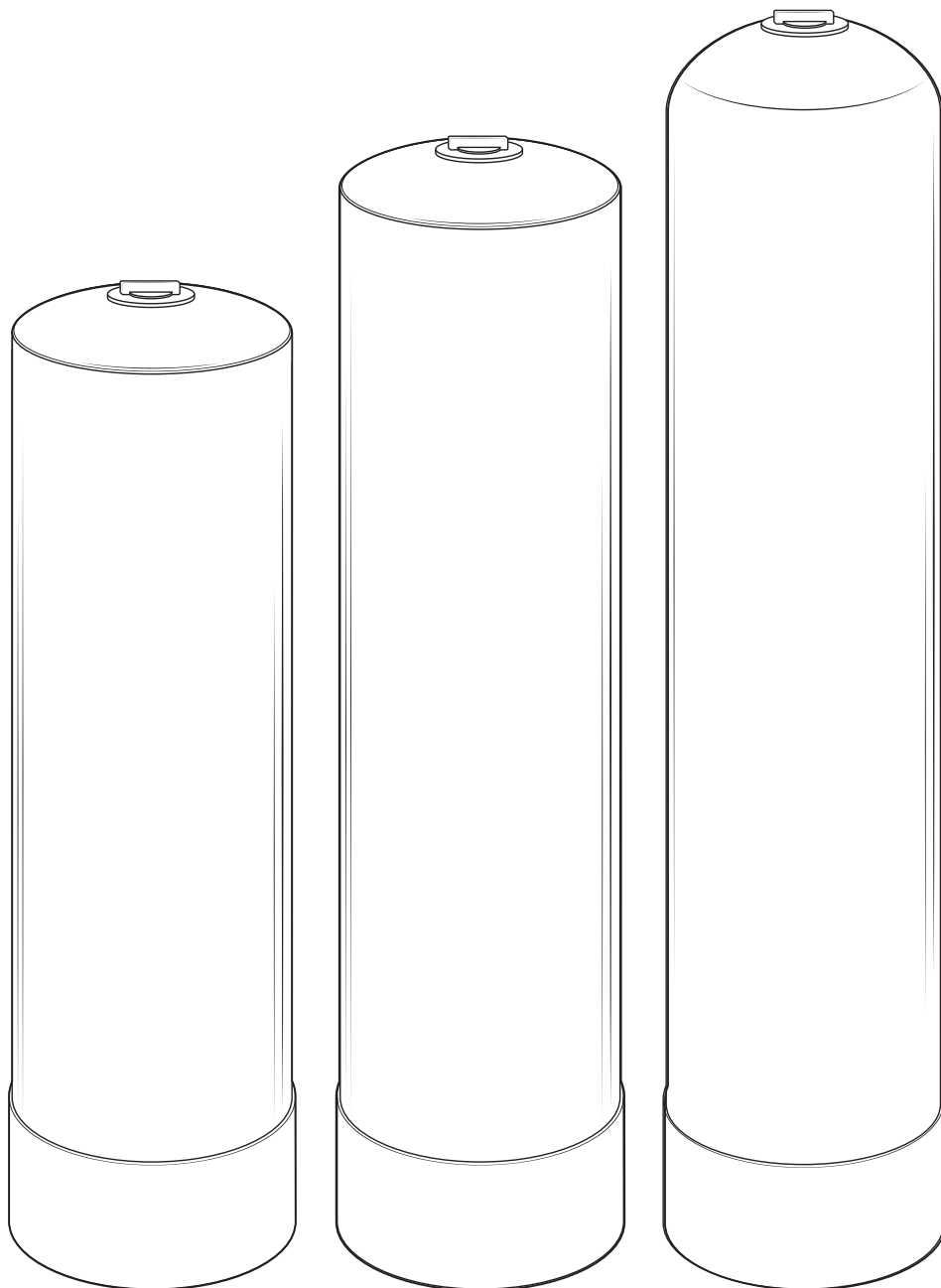

# Series 4 Mixed Bed Carbon System



Models: (Series 4) K150-010

# Introduction

---

Thank you for your purchase of the Radiant Life carbon filtration system. We highly recommend opening all packages of the shipment and verify that all required parts have arrived are inspected for damage **before** contacting an installer and scheduling an appointment. This manual covers the installation and operating instructions for the following models:

- Series 4: K150-010 (2.0 cu ft)

We recommend contacting our Water Service Department (888-593-9595 option 2) once you have scheduled an installation appointment so that we can ensure one of our technicians are available if needed.

## Overview

The Series 4 Mixed Bed Carbon Filtration Systems are designed to provide years of protection from chemicals, bad tastes, odors, and color. They are also specifically designed to remove trace chemicals such as chlorine or chloramines introduced into the water by municipal treatment plants as a means of disinfection. These chemicals create taste and odor issues and carcinogenic compounds that are harmful when consumed or absorbed into the body.

The Series 4 units have the added ability to reduce fluoride and heavy metals. Water containing chemicals from agricultural cultivation may also enter into the water supply, these systems are designed to reduce these contaminants as well. The systems are meant for installation at the entry point of water coming into the home whereby it can treat your entire home for both hot and cold water.

## Benefits our Mixed Bed Carbon Water Filtration Systems

- Water quality is enhanced
- No chemicals
- Removes bad tastes and odors
- Retains essential minerals
- Simple installation
- Minimal maintenance
- Protects water using appliances
- Takes very limited space
- Compatible with all on-site/community waste water treatment systems

## Important Safety and Installation Information

---

Exposure of the filters to freezing temperatures (32°F, 0° C) or temperatures exceeding 110°F (37.8° C) may damage the tank and cause the system to malfunction. Always install the tank where the temperature is above freezing and below 110°F (37.8° C). **Insulate the system and plumbing when installed outdoors or in extreme climates. It is imperative that the tank not be exposed to extreme temperature swings that can cause expansion and contraction, which may result in cracks in the tank. If left unprotected, it may affect the validity of your warranty.**

High water pressure may cause plumbing leaks and potentially damage the Water Filtration System. The maximum recommended water pressure is 80 psi. If the pressure exceeds 80 psi a pressure reducing valve must be installed.

Installation and use of the system must comply with all state and local plumbing codes. If necessary, contact a local plumber for advice or help with installation.

# Product Components

Check that the following parts are included in your package(s). Inspect all parts for damage.

- A. Pre-loaded water filter tank with cap
- B. Tank head with upper basket
- C. Bypass valve
- D. Spin down filter
- E. Installation elbows

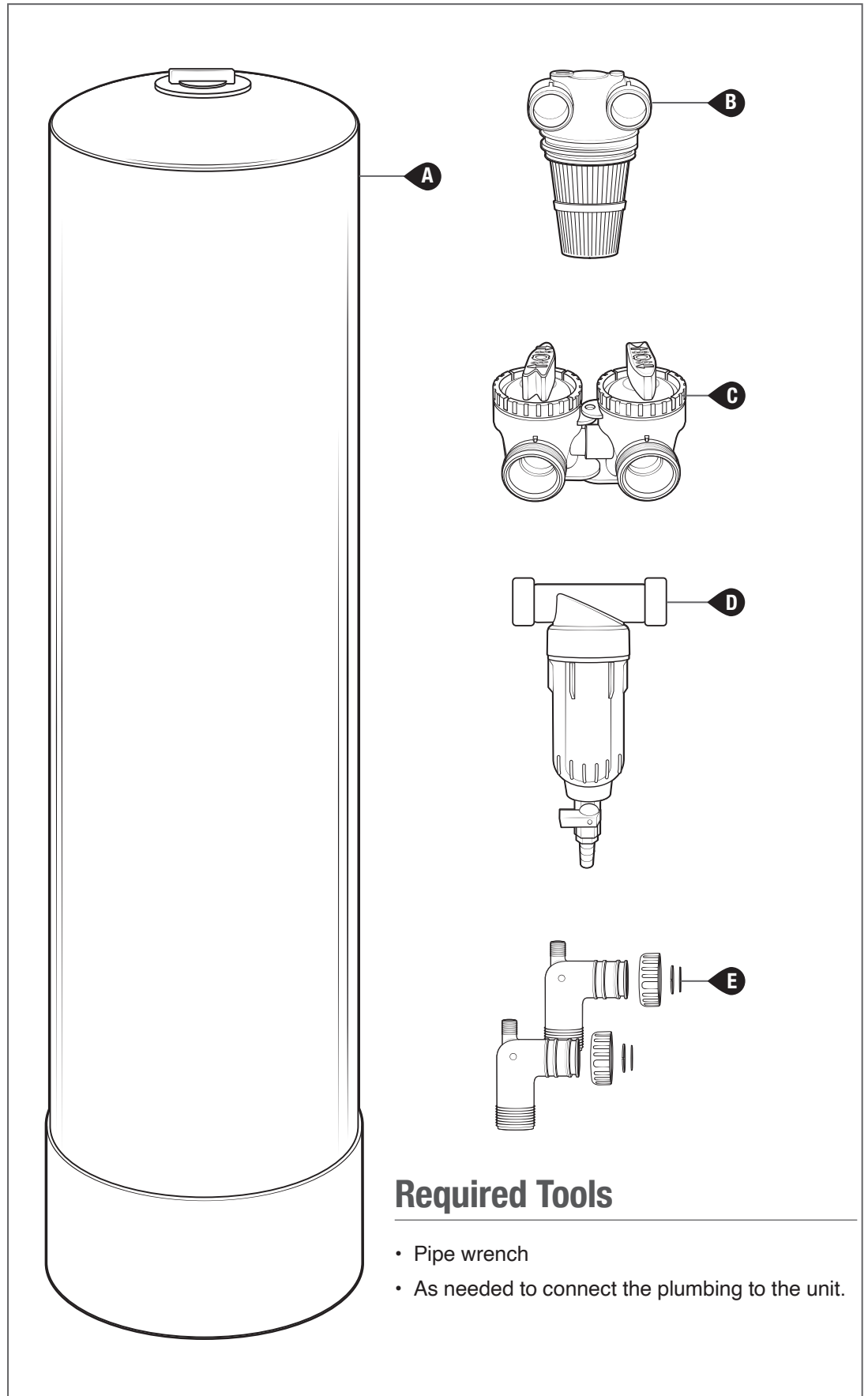

# Installation

**Important!** Failure to follow these instructions, or use of parts other than genuine Radiant Life components, will void the warranty.

**Failure to install the spin down filter or another appropriate sediment filter will void the warranty for the Whole House Filtration System.**

## Step 1 Pre-Installation

1. Open all the packages and verify the parts against parts shown in the Parts section. Inspect all parts for damage.

**Note:** If you purchased the Whole House Filter System along with one of our Whole House Conditioners, the Spin Down Filter and Whole House Filter System is installed **before** the Conditioner. We recommend having a bypass installed for easy maintenance or if the system is removed.

2. Turn off the water supply to the house.

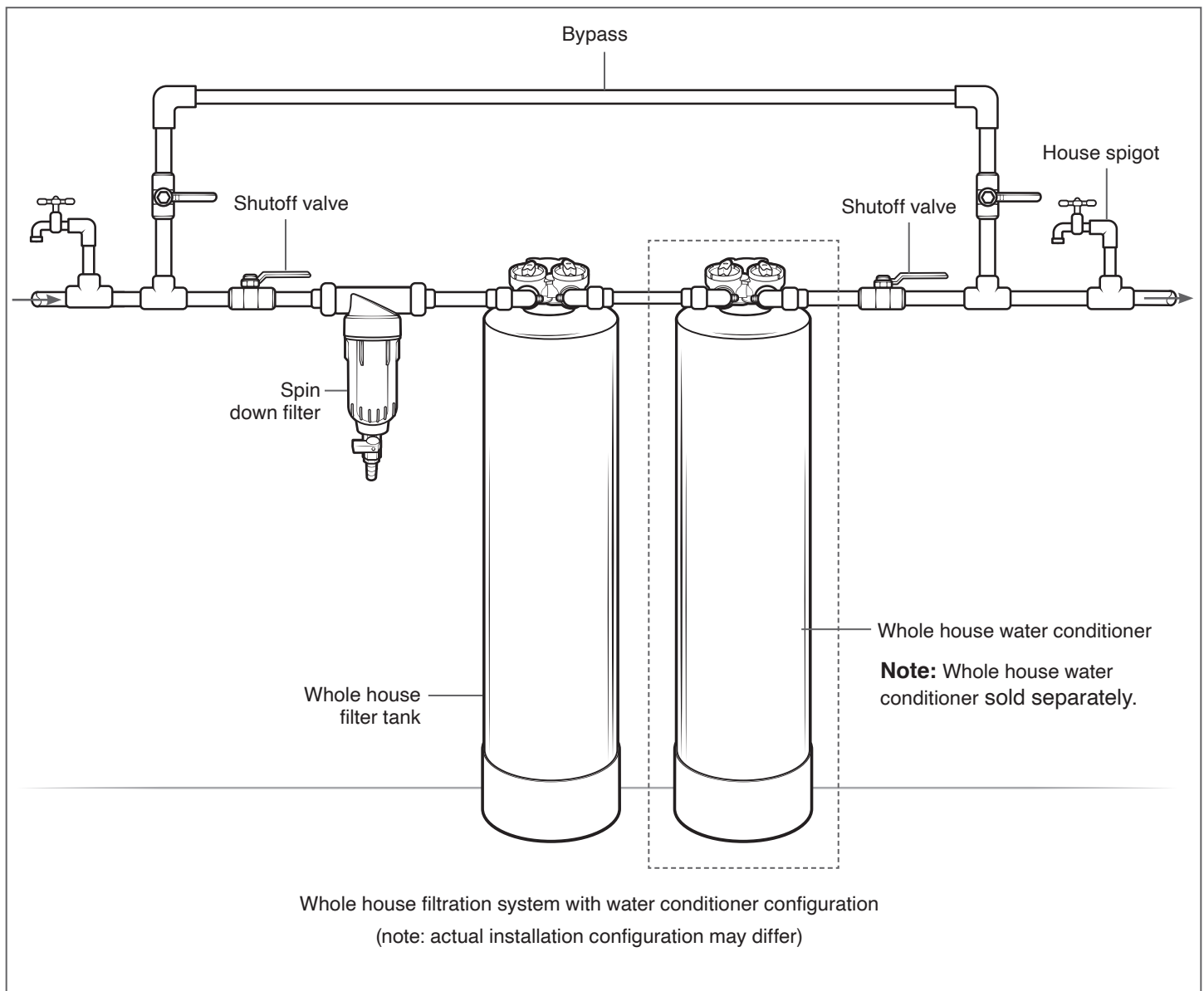

## Step 2 Install the Spin Down Filter

**Important!** The Spin Down Filter must be located **before** the Filter Tank and, if purchased, the Whole House Conditioner System. We also recommend having your installer use some type of bypass set up in case maintenance/repair is needed on the Spin Down Filter.

**Note:** Refer to the OEM manual of the Spin Down Filter for installation instructions.

1. Determine the location of the Spin Down Filter and mark the location of the mounting holes on the mounting bracket. **Important!** The Spin Down Filter will rest on top of the mounting bracket. Position the bracket so the Filter inlet and outlet are in-line with the connecting pipes.
2. Drill pilot hole for the screw and mount the Spin Down Filter mounting bracket. **Note:** Drywall anchor and mounting screw provided if needed.

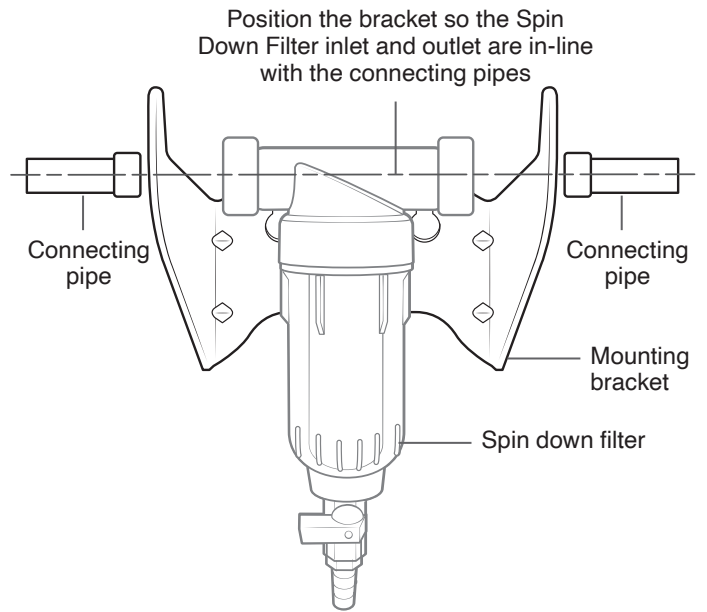

## Step 3 Attach the Tank Head to the Filter Tank

1. Place the Tank Head (with Upper Basket) over the Riser Tube in the Filter Tank.
2. If necessary, gently tap on the Tank Head until the male threads on the Tank Head meet the female threads on the Filter Tank.
3. Attached the Tank Head to the Filter Tank by rotating it clockwise. Firmly, hand tighten the Tank Head to the Filter Tank until completely sealed. **Note:** If “hand tight” does not completely seal the joint between the tank and Tank Head, watch the following video showing one method to secure the Tank Head to the Filter Tank: <https://youtu.be/ZGgVOWJem6k>

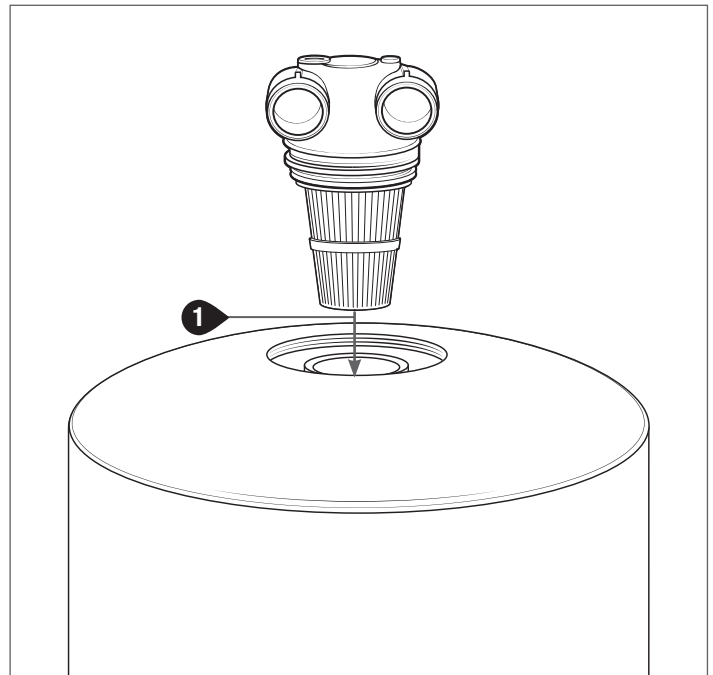

## Step 4 Attach the Bypass Valve to the Filter Tank

1. Push the Bypass Valve into the Tank Head on the Filter Tank. Fasten using the attached knurled nuts.

**Note:** The Bypass Valve will only connect to the system in one direction. The system is designed to operate in a **DOWNFLOW** configuration. It is most important for proper installation that the incoming water supply is connected to the **INLET** labeled side on the unit and the outgoing water supply to the home is connected to the **OUTLET** labeled side on the unit.

2. Place the Bypass Valve in the **SHUT OFF** position.

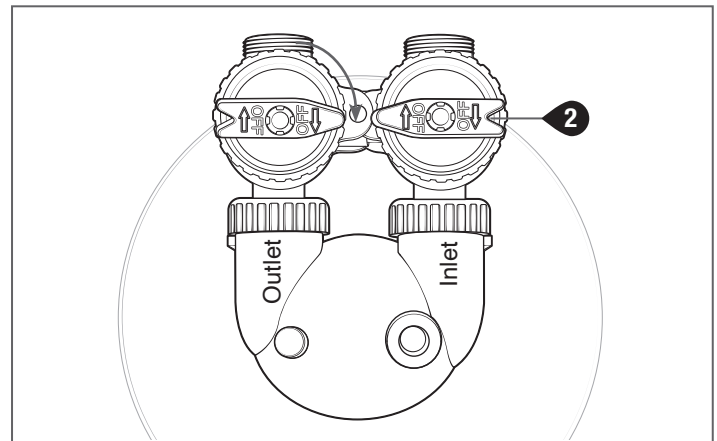
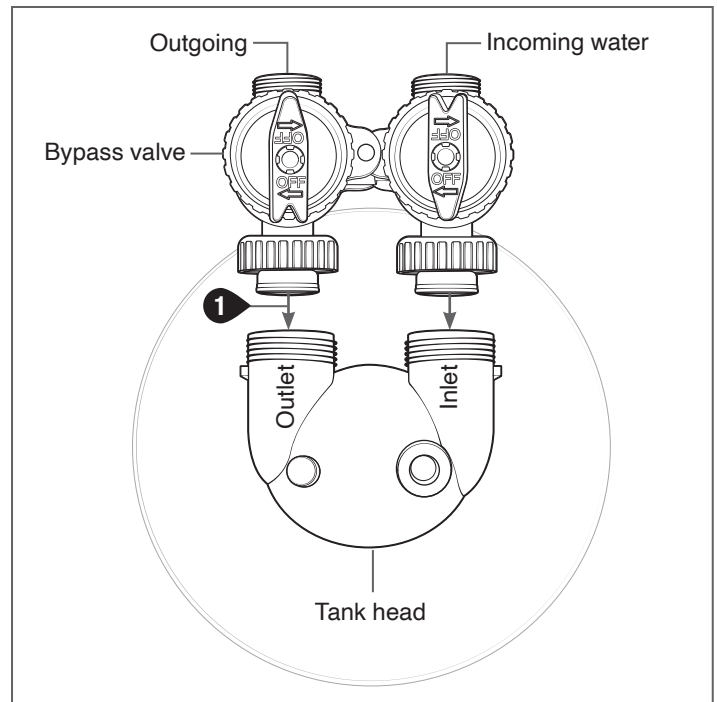

## Step 5 Attach the Installation Elbows

1. Place the knurled nut onto the Installation Elbow.
2. Place the white snap-ring onto the Installation Elbow.
3. Place the black o-ring onto the Installation Elbow.
4. Insert the Installation Elbow assembly into the inlet port on the Bypass Valve. Fasten the Installation Elbow to the Bypass Valve using the knurled nut.

**Note:** The Installation Elbow can be rotated in any direction for ease of installation.

5. Repeat steps 1–4 for the outlet port.

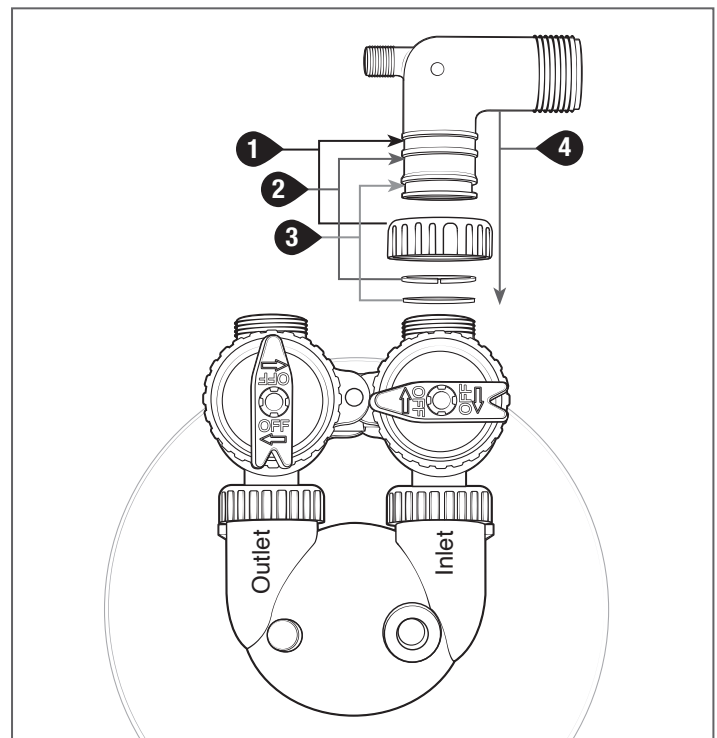

## Step 6 Connect the Water Supply

**Important!** If you are installing the Conditioner with our Whole House Water Filter System, ensure that the filter tank has been thoroughly flushed **before** connecting the outlet of the filter tank to the inlet of the conditioner tank.

Ensure that the conditioner head is securely tightened to the tank prior to attaching to the water supply. If not secure, leaking may occur between the tank and conditioner head.

1. Connect the plumbing to the inlet side of the system.  
**Note:** Do not connect the plumbing to the outlet side at this time.

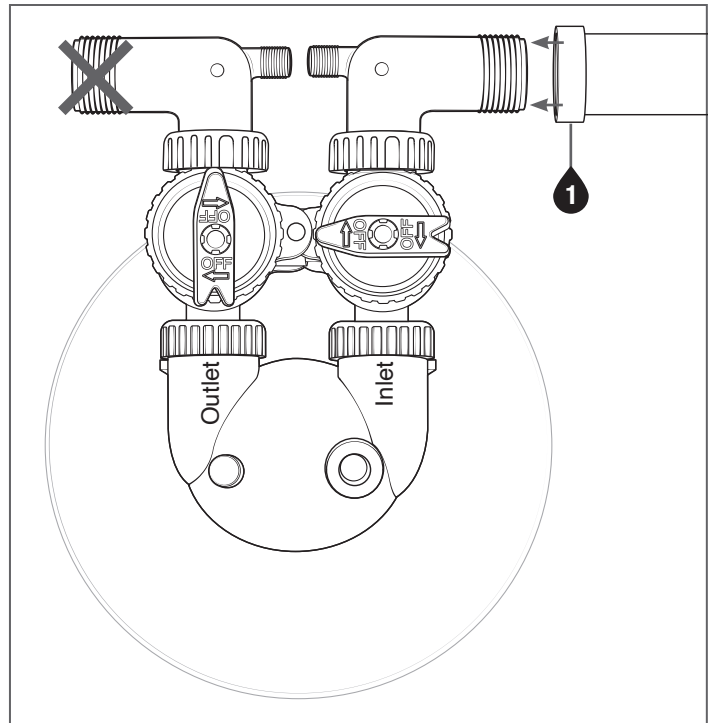

## Step 7 Flush the Filter Tank

**Important!** The system media is shipped dry. Before placing this unit into service, it must be flushed to a drain or outlet where the dust and greywater that occurs when water first comes into contact with this system can be discarded.

Connecting the plumbing to both the inlet and outlet valves without flushing the unit **will** result in excess carbon fines and dark colored water inside the home.

It will take several hours or longer to flush these materials from the plumbing if introduced to the home.

1. Attach the provided garden hose fitting onto the outlet valve Elbow Adaptor.
2. Attach a garden hose that can reach the drainage point.
3. Turn on the water supply and check for leaks. If necessary, tighten the connections.
4. Slowly turn the inlet side knob on the Bypass Valve to the NORMAL OPERATION position.

After a short time (depending on incoming water pressure), water should begin flowing from the garden hose.

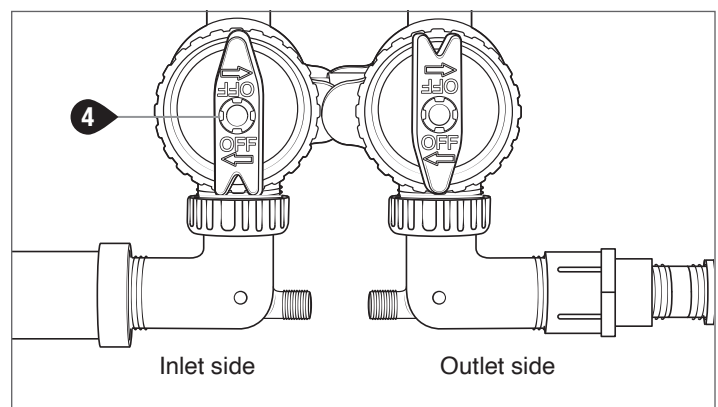
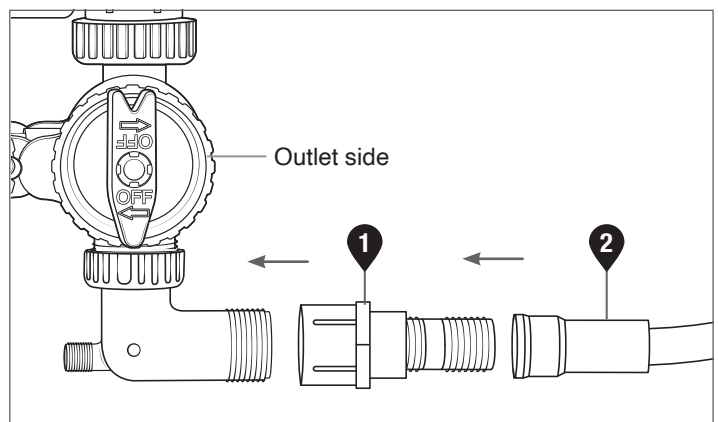

5. Once the water is running clear, turn the inlet knob on the Bypass Valve to SHUT OFF MODE position.
6. Allow the water & media to settle, about 5 minutes. Then open and shut-off the inlet side knob to flush the tank as follows:
  - Apply 3 to 5 short bursts. **Note:** A burst is on for 25 to 30 seconds and then off for 25 to 30 seconds.
  - Apply a final flush of at least a couple minutes, or until the water runs clear (i.e.: no more grey water or carbon fines).
7. To ensure the filter is flushed, we recommend running the water through a white cloth until no carbon fines can be seen. When clear, rotate the inlet valve to SHUT OFF position
8. Remove the garden hose and garden hose fittings.

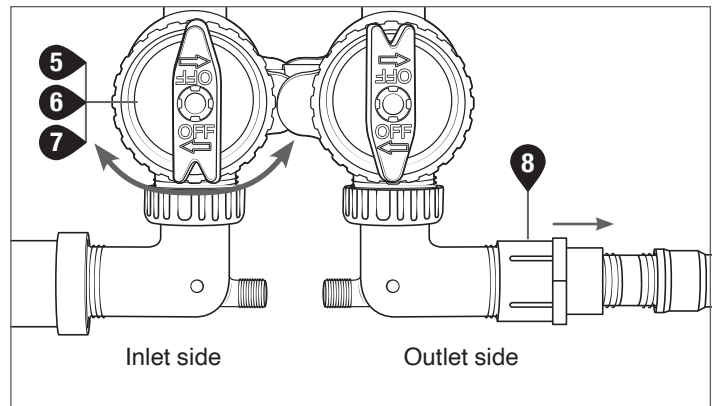

## Step 8 Connect the Water Supply to the Outlet Valve

1. Connect the plumbing to the outlet side of the system.
2. Open the closest faucet to the water filter COLD SIDE ONLY to expel the air in the system.
3. Slowly turn the inlet side of the Bypass Valve to the NORMAL OPERATION position.
4. Check for leaks. If necessary, tighten the connections.

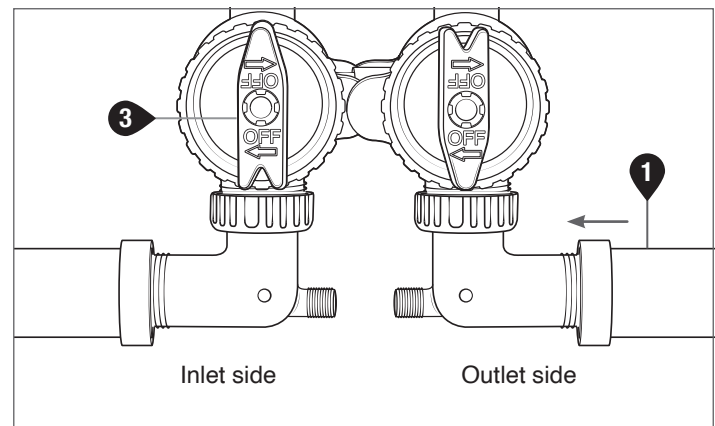

## Common Questions

### Why does the water appear cloudy?

Once the water filter system is installed and filtering water to your home, the water may appear cloudy. This is nothing to be concerned about. The media inside the system has never been wet and will have air trapped throughout. As the media becomes saturated, this air is gradually expelled creating a cloudy look that will dissipate and cease in time.

### How do I know it is working?

The quickest and easiest way to determine if the system is working is to test for chlorine removal. This can be done when the home is on a city supplied water system using chlorine test strips or pool test kit. Test the incoming water by getting water from the bottom of the spin down filter. Test the water in the home after it has travelled through the water filter. This test is best done after allowing the system to replenish the entire home with water to ensure no unfiltered water remains in the plumbing.

If on a well water system, a known water contaminant would need to be tested before and after the system to determine removal rate. This would be based on the Model/Series purchased.

### Can I use a TDS (Total Dissolved Solids) meter to test the Whole House Water Filtration System?

This filtration system is designed to remove contaminants from the water while leaving essential minerals, such as calcium and magnesium, in the water. TDS meters register the organic materials in the water which is mainly comprised of minerals the water has absorbed. Because the filter is designed to leave these minerals, very little or no change in TDS will occur. Therefore, testing with a TDS meter will not reflect whether the system is functioning or not.



# Bypass Valve Operation

The bypass valve is typically used to isolate the Tank Head from the plumbing system's water pressure in order to perform Tank Head repairs or maintenance. The WS1 bypass valve is particularly unique in the water treatment industry due to its versatility and state of the art design features. The 1" full flow bypass valve incorporates four positions including a diagnostic position that allows service personnel to work on a pressurized system while still providing untreated bypass water to the facility or residence. It's completely non-metallic, all plastic (Food Grade/BPA Free) design allows for easy access and serviceability without the need for tools.

The bypass body and rotors are glass filled Noryl and the nuts and caps are glass filled polypropylene. All seals are self-lubricating EPDM to help prevent seizing after long periods of non-use. Internal O-rings can easily be replaced if service is required.

The bypass consists of two interchangeable plug valves that are operated independently by red arrow shaped

handles. The handles identify the flow direction of the water. The plug valves enable the bypass valve to operate in four positions.

**Normal Operation Position:** The inlet and outlet handles point in the direction of flow indicated by the engraved arrows on the Tank Head.

**Bypass Position:** The inlet and outlet handles point to the center of the bypass, the tank is isolated from the water pressure contained in the plumbing system. Untreated water is supplied to the plumbing system.

**Diagnostic Position:** The inlet handle points in the direction of flow and the outlet handle points to the center of bypass valve, system water pressure is allowed to the tank and the plumbing system while not allowing water to exit from the tank to the plumbing.

**Shut Off Position:** The inlet handle points to the center of the bypass valve and the outlet points to the direction of flow, the water is shut off to the plumbing system.

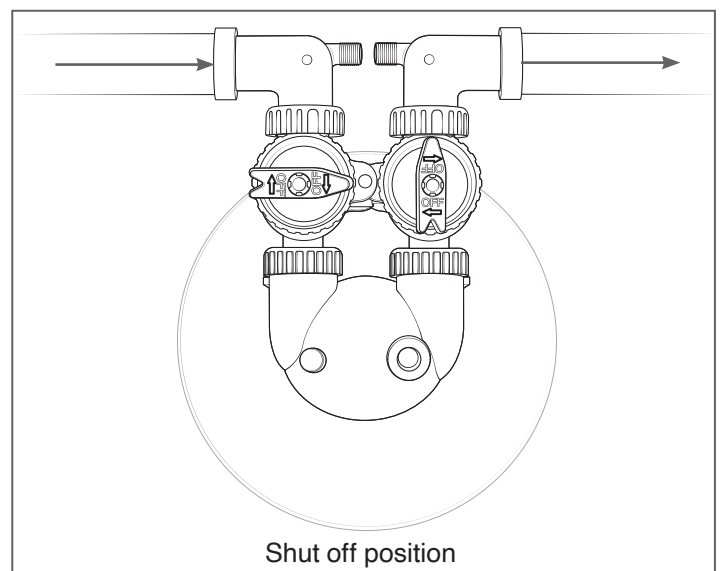
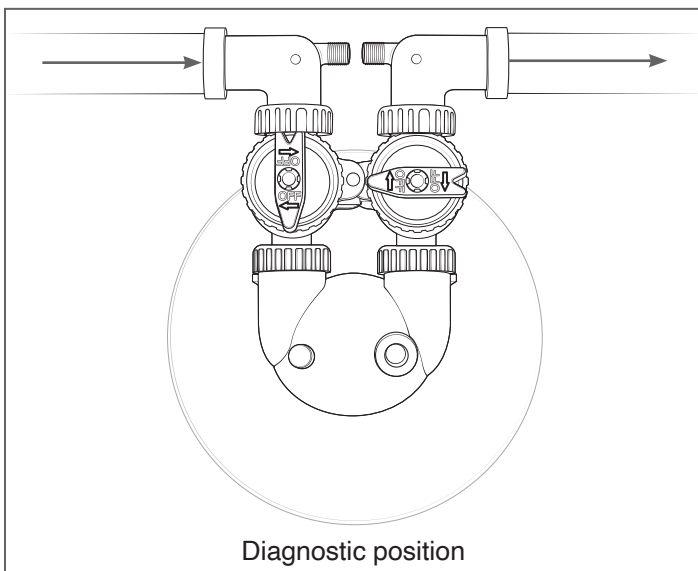
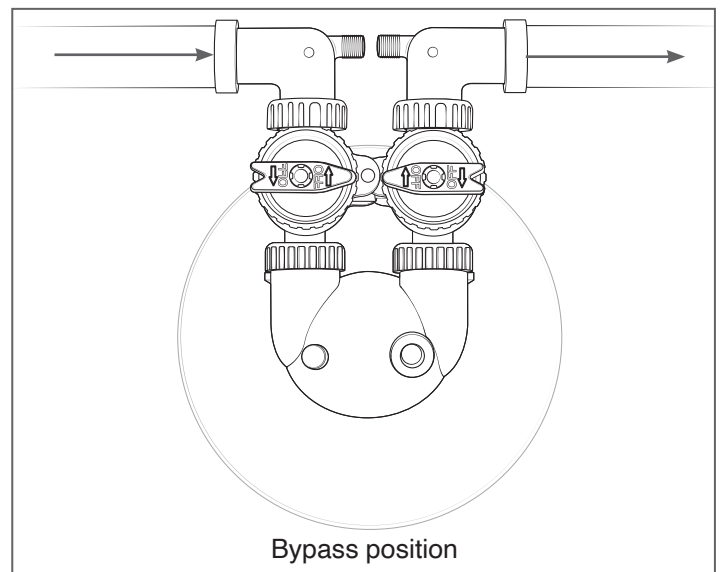
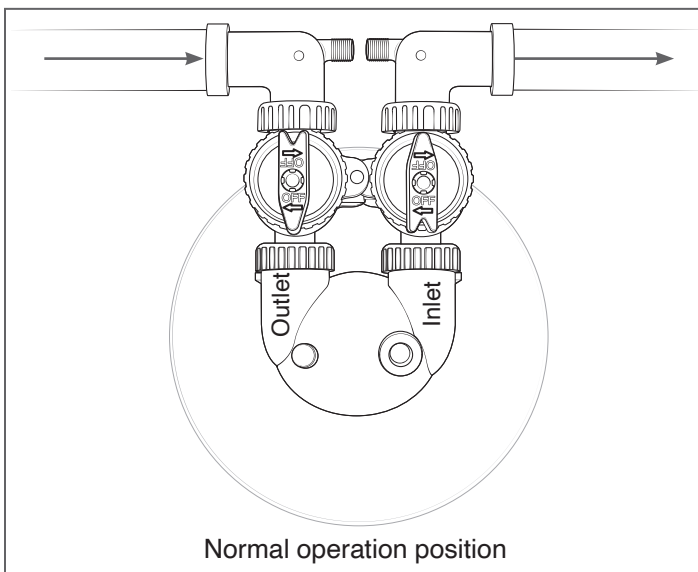

# Maintenance

The Radiant Life Water Filtration System with its large capacity tank and specialized media is designed to be nearly maintenance free. Water supplies, delivery conditions, pipe breaks and standard maintenance may affect the water supply, requiring minor maintenance periodically. Long-term maintenance is testing the water to ensure proper filtration and to determine when the media should be changed.

## Spin Down Filter

The spin down filter is installed in front of the Whole House Filtration System to protect it from larger sediment particles that could potentially clog the internal components. It is imperative that this, or another sediment filter, be installed before the Whole House Filtration System to protect it.

**Failure to install an appropriate sediment filter will void the warranty for the system.**

It may be necessary to drain the spin down filter housing of any built-up sediment particles. Sediment may build up from being present in the water supply, because of broken water pipes and/or system repairs. Locate the spin down filter and observe the clear housing to see if there is any sediment or materials attached to the filter inside. To drain the spin down filter, use a bucket or connect filter to a drain, open the black handle at the bottom, close when sediment is cleared.

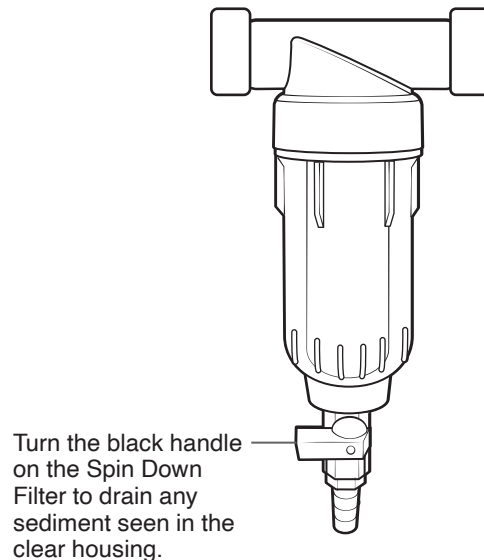

## Media Testing

The media in the tank will need to be changed periodically. On average the media in the tank will last 5-10 years, depending on the incoming water conditions and amount of water filtered. We recommend periodically testing the filter to determine how well it is functioning. If receiving city supplied water, use Chlorine test strips to monitor chlorine levels after the filter. When the system is new, chlorine will be reduced to a non-detectable level. When the media has become saturated with contaminants, chlorine levels will increase indicating it is time to change the internal media. We suggest using chlorine test strips, which can be purchased on our website at [www.radiantlifecatalog.com/test-strips-chlorine](http://www.radiantlifecatalog.com/test-strips-chlorine). A pool chlorine test kit can also be used.

If using well water, testing for chlorine is not possible, unless the water is continually sterilized using chlorine. Under these circumstances, the well water will need to be tested before and after for one specific contaminant, such as lead, to determine if it is time for media change. If testing is not practical, we suggest replacing the media every seven (7) years.

## Media Replacement

Please contact Radiant Life technical support to obtain replacement options.

# Warranty

---

## Warranty Scope

Radiant Life warranties to the original purchaser that the Water Filtration System will be free from defects in materials or workmanship in manufacturing except as noted below. During the Warranty Period and subject to the limitations and exclusions set forth below, Radiant Life will, at its option, replace the product or refund the product purchase price if the product fails to satisfy this Limited Product Warranty. No labor to install, test or replace components is covered under this warranty.

The Filtration media carries a pro-rated warranty against defects for a period of five (5) years from the date of purchase. Proof of purchase is required for warranty service.

The digital controls, heads and valves are covered by a 5-year warranty against defects in materials and workmanship.

The tank is cover by a 10-year warranty against defects.

## Warranty Conditions

The product was installed and operated within the operating conditions specified in the installation manual. The individual invoking the warranty is the original purchaser of the Water Filtration System.

The system has been properly maintained, according to the Instruction and Owner's Manual. The amounts of impurities present in the local water supply may require that the media be replaced on a more frequent basis.

## What is not Covered

No warranty is given as to the service life of any filter or media as this will vary depending on incoming water quality and volume of water treated.

This warranty does not cover filters that were not installed according to the instructions provided with your system, operated incorrectly, abused, or improperly maintained.

This warranty also does not cover the following items:

- Performance due to water conditions
- Incidental or consequential damages caused by failure of the product
- Labor costs to install or replace the filters, media, or system
- Damages caused by fire, flood or acts of God
- Damage from non-potable water supplies
- Damages caused by any person

This warranty is voided if the product is not installed with genuine Radiant Life components and in accordance with the provided instructions. This includes, but is not limited to, media, filters, valves, and tanks.

## Limitations and Exclusions

Except as otherwise expressly provided above, Radiant Life makes no warranties, expressed or implied, arising by law or otherwise, including without limitation the implied warranties of merchantability and fitness for a particular purpose, to any person. This Limited Product Warranty may not be altered, varied or extended except by written instrument executed by Radiant Life. The remedies of replacement or refund of the Product purchase price are exclusive and are the sole obligations of Radiant Life under this Limited Product Warranty. Radiant Life will not be liable for any loss or damage arising from installation and use of the Product, whether direct, indirect, special, incidental, or consequential, regardless of the legal theory asserted, including warranty, contract, negligence, or strict liability. Some states and countries do not allow the exclusion or limitation of incidental or consequential damages, so the above limitation may not apply to you.

## How to get service

To receive assistance with your water system and warranty, contact the Water Service Team at 888-593-9595 Opt. #2 or email [waterservice@radiantlife.com](mailto:waterservice@radiantlife.com). Be prepared to provide account details, purchase date, and describe the problem to the representative. Pictures or testing may be required to verify the warranty. Once the warranty is approved, it will be determined if a new part or system will be replaced at no cost to you.

## Customer Service

---

**Radiant Life**

**Address:** 5277 Aero Dr. • Santa Rosa, CA 95403

**Phone:** (888) 593-9595 Option 2

**Fax:** (707) 433-8898

**Email:** [waterservice@radiantlife.com](mailto:waterservice@radiantlife.com)

